



HARVESTER HEADS

H742 | H752 | H270 | H290 | 745 | H754 | 758HD | H480



Efficient and Productive John Deere Harvester Heads

Efficient John Deere harvester heads are precision tools that fulfil the strict quality requirements of the industry in all operating conditions. The product range caters for all applications – from small-scale thinning to extensive regeneration felling.

From our range of four 2-roller driven harvester heads and four 4-roller driven harvester heads you will always find the most productive option for your John Deere harvester, regardless of the machine and the stand. John Deere harvester heads feature all the properties required for modern harvesting.

John Deere harvester heads have been global pioneers in harvesting technology for almost 30 years. The expertise of John Deere's customer services ensures the continued productivity, reliability and low operating costs of your harvester heads.

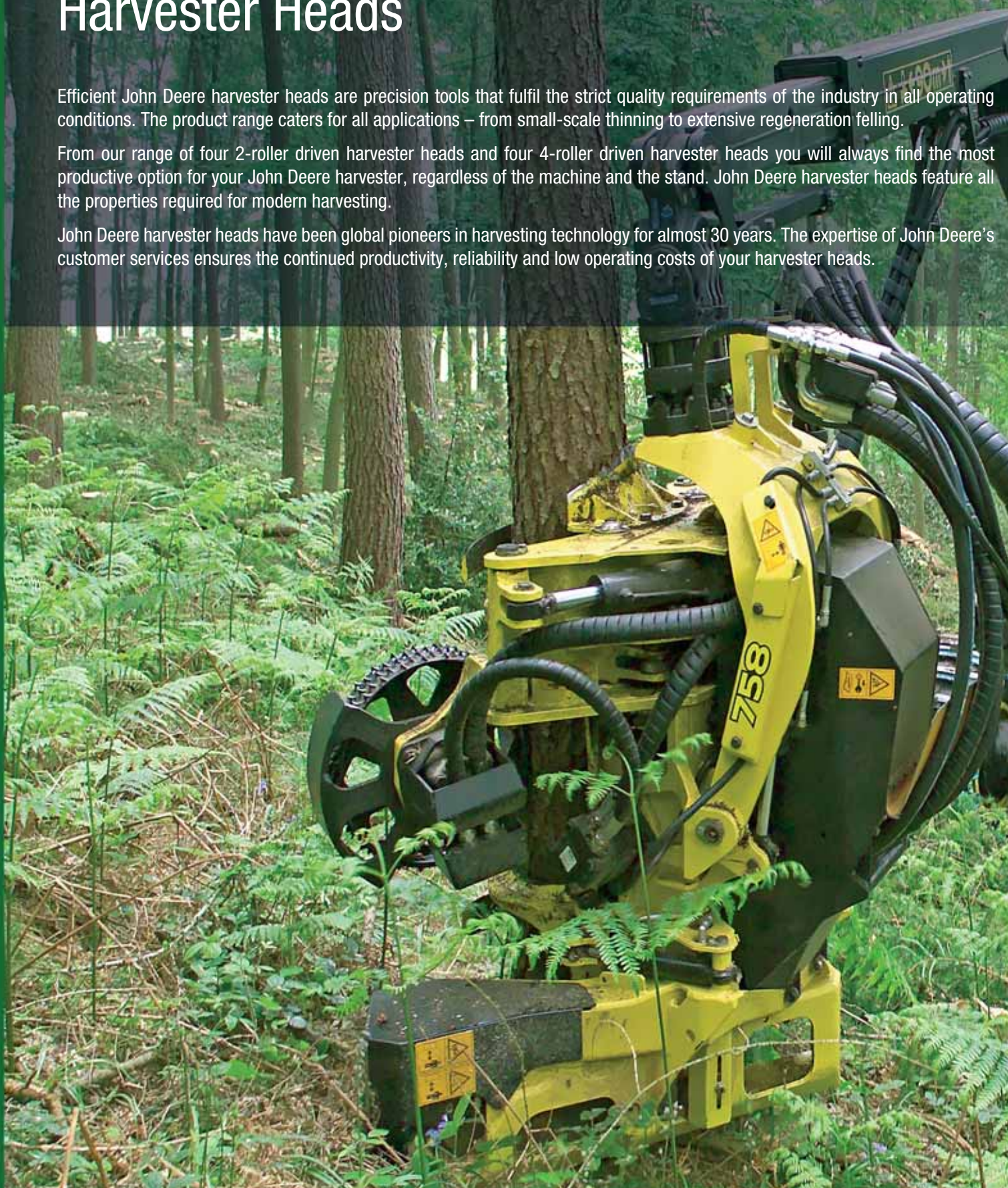



- John Deere's range of harvester heads has a hardwearing and efficient option for all forest machines in all kinds of stands.
- Designed for processing large trees
- Performance and productivity
- Low fuel costs

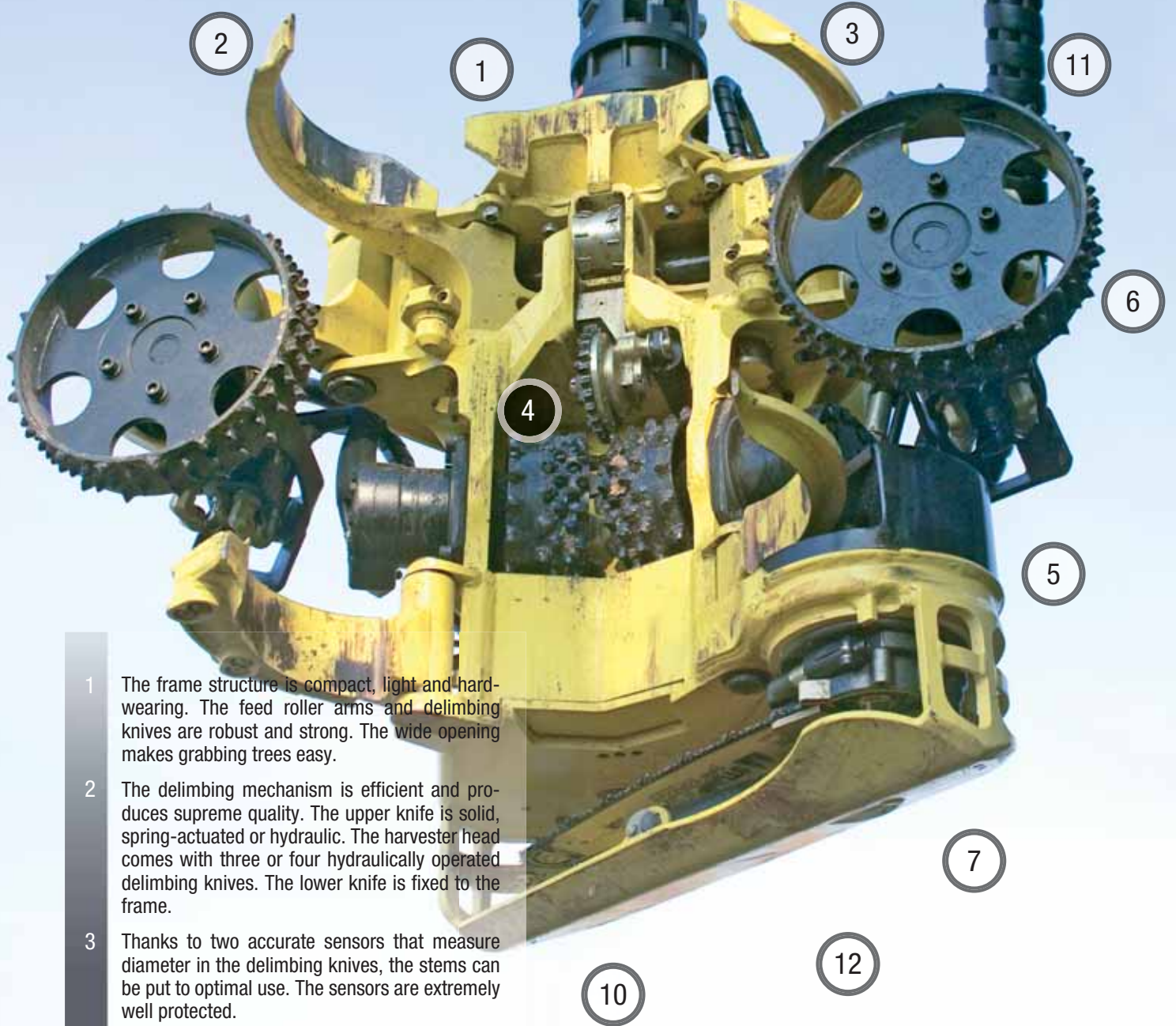

- 1 The frame structure is compact, light and hard-wearing. The feed roller arms and delimiting knives are robust and strong. The wide opening makes grabbing trees easy.
- 2 The delimiting mechanism is efficient and produces supreme quality. The upper knife is solid, spring-actuated or hydraulic. The harvester head comes with three or four hydraulically operated delimiting knives. The lower knife is fixed to the frame.
- 3 Thanks to two accurate sensors that measure diameter in the delimiting knives, the stems can be put to optimal use. The sensors are extremely well protected.
- 4 The length measurement mechanism is exceedingly accurate. The weighting system is either hydraulic or spring-actuated. Several measuring wheel alternatives are available.
- 5 Thanks to its short structure, the harvester head follows the contours of the stem meticulously during delimiting.
- 6 Friction between the harvester head frame and the stem is minimal. The four-roller driven feeding mechanism works effectively and without slipping even on bent stems. The process starts aggressively. The harvester heads come with two moving feed rollers and two feed rollers fixed to the frame.

Quality, Power, Easy Maintenance – High Uptime

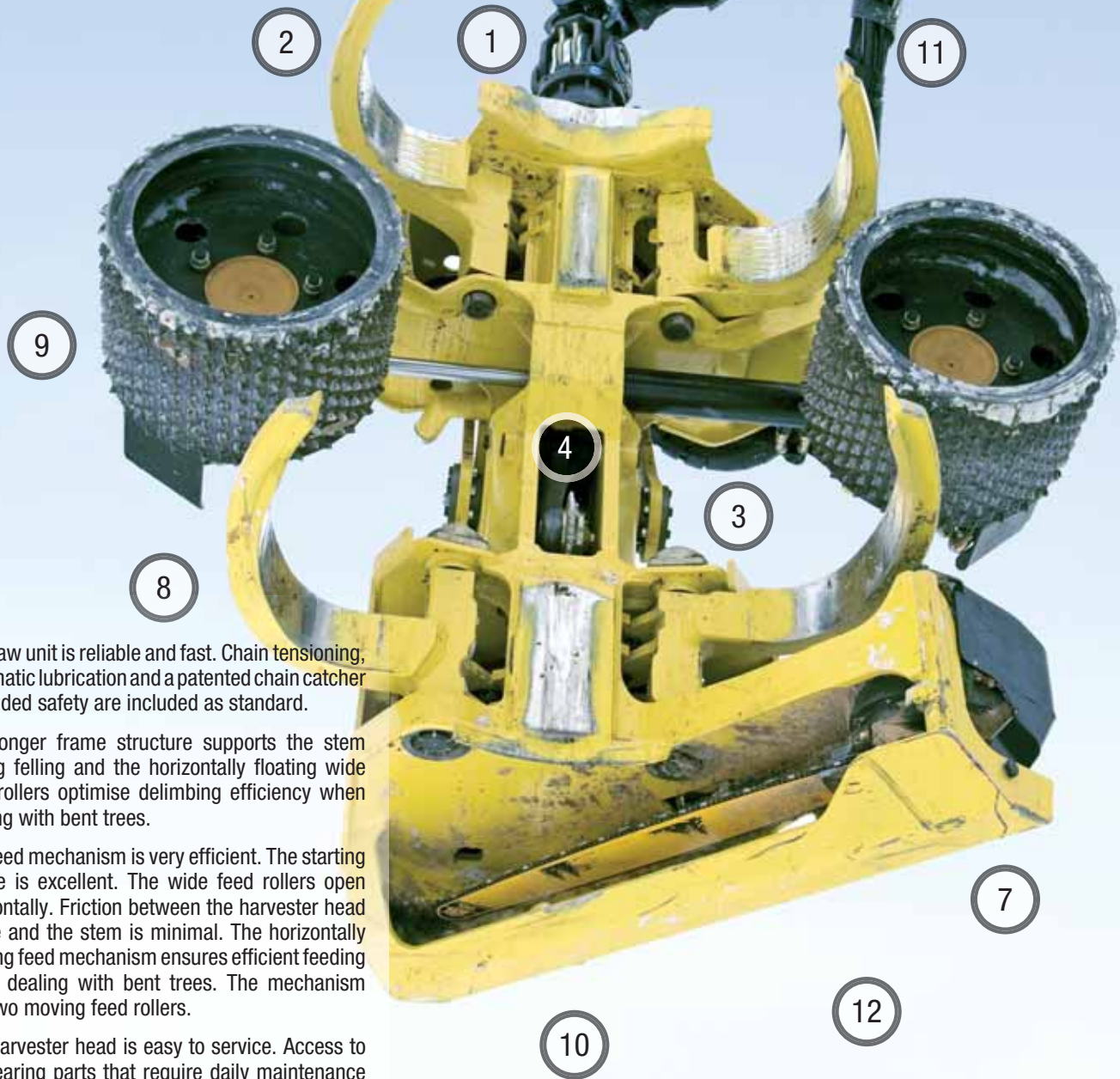

- 7 The saw unit is reliable and fast. Chain tensioning, automatic lubrication and a patented chain catcher for added safety are included as standard.
- 8 The longer frame structure supports the stem during felling and the horizontally floating wide feed rollers optimise delimiting efficiency when dealing with bent trees.
- 9 The feed mechanism is very efficient. The starting torque is excellent. The wide feed rollers open horizontally. Friction between the harvester head frame and the stem is minimal. The horizontally floating feed mechanism ensures efficient feeding when dealing with bent trees. The mechanism has two moving feed rollers.
- 10 The harvester head is easy to service. Access to all wearing parts that require daily maintenance is easy. The hoses are enclosed in a protective conduit to minimise damage.
- 11 The hydraulic valve has been optimised for use in harvester heads. Proportional adjustment ensures precise settings. Pressure strength is high and power loss minimal. The valve is well protected yet easily accessible in its casing.
- 12 A wide array of accessories is available.

Powerful Feeding

John Deere harvester heads come with efficient feed motors that withstand high hydraulic pressures. The high starting torque ensures that the feeding mechanism works with full power from the start. Friction between the harvester head frame and the stem is minimal both with two-roller and four-roller driven feeding mechanisms. The feed roller arms have been designed to withstand constant hard work. Various feed motor and feed roller options for different kinds of stands are available as accessories.



Efficient, High-quality Delimiting

Thanks to the delimiting knives of John Deere harvester heads being suitable for all sizes of stems, the proportional control that adapts to the diameter of the stem and the separate valve block in the lower knives, stems are delimited with precision. The large opening facilitates grabbing the stem. The multi-tree handling equipment enables several stems to be processed simultaneously on thinning stands.



- Valve specifically designed for use in harvester heads
- Efficient feeding and high-quality delimiting
- Performance and productivity
- Different sized feed motors and a variety of feed rollers to meet all needs

Fast Cutting Ensures Quality

The reliable and fast saw unit ensures high quality in cutting. Thanks to the Timbermatic 300 control system, the cutting power can be regulated with excellent accuracy, with different operating pressures for small and large timber. Chain tensioning and automatic lubrication as well as a patented chain catcher for added safety are available as standard. The stump treatment and colour marking systems as well as the intelligent FlashCut sawing control system that improves cutting efficiency and minimises cracks are available as accessories. The accurate saw control and monitoring systems lengthen the lives of both the chain and the motor.



Timbermatic 300 is an easy-to-use measurement, control and communications system for John Deere harvesters.

Intelligent user-friendliness

Straightforward controls for feeding and cutting

High harvester head performance and productivity



Accurate Length and Diameter Measurement

Thanks to the optimised, proportional settings of the hydraulic valve, the harvester head functions can be controlled with precision. The valve offers high pressure strength and little pressure loss. The valve is well protected yet easily accessible in its casing. Adjusting the harvester head's settings to suit specific trees and stands is easy, thanks to the Timbermatic 300 system in the cab. Settings include saw functions, positioning the stem on the rollers and the delimiting knives on the basis of a diameter-based graph, and a variety of automated control settings for feeding and cutting.

Thanks to the two sensors in the delimiting knives that accurately measure the diameter of the stem and the measuring wheel in the middle of the harvester head that takes the length measurement, the stem can be put to optimal use. The sensors are extremely well protected. The volume measurement can be calibrated accurately with user-friendly electronic calipers when needed.

Technical Data

4 Rollers

FELLING/CUTTING	745	H754	758HD	H480
Saw motor	19 cm ³	19 cm ³	19 cm ³	19 cm ³
Length of saw bar	640–750 mm	640–750 mm	750–825 mm	750–825 mm
Cutting diameter	550–620 mm	550–620 mm	650–720 mm	650–720 mm
Chain type	0.404"	0.404"	0.404"	0.404"
Chain speed	40 m/s	40 m/s	40 m/s	40 m/s
Oil tank capacity	7 l	6 l	12 l	12 l
Saw options				
OM saw unit	Yes	Yes	Yes	Yes
SuperCut	Yes	Yes	Yes	Yes
FlashCut	No	Yes	Yes	Yes

DELIMBING				
Delimiting knives				
Frame, upper knives	1 fixed	1 fixed	1 fixed/hydr.	1 fixed/hydr.
Above the feed rollers	2 moving	2 moving	2 moving	2 moving
Beneath the feed rollers	1 moving	2 moving	2 moving	2 moving
Frame, lower knives	1 fixed	1 fixed/spring actuated	1 fixed	1 fixed

MEASURING				
Length	Rib or spike roller with spring actuated or hydraulic weighting			
Diameter	From front delimiting knives	From front delimiting knives	From front delimiting knives	From front delimiting knives

ACCESSORIES				
Colour marking				
2 colours, nozzle/delimiting knives	Yes	Yes	Yes	Yes
2 colours, saw bar	Yes	Yes	Yes	Yes
3 colours, saw bar	Yes	Yes	No	Yes
Stump treatment	From the saw casing via the saw bar or a nozzle			
Multi-tree handling	Yes	Yes	Yes	No
Other accessories	For more information on the accessories, please contact our resellers.			

MEASUREMENTS* [mm]				
A Length of the delimiting unit	980	1 130	1 330	1 330
B Width with rollers open	1 280	1 360	1 650	1 650
C Opening, feed rollers	560	560	680	680
D Opening, upper delimiting knives	560	560	680	680
E Opening, lower delimiting knives	580	580	710	730

WEIGHT without rotator, from				
	780 kg	820 kg	1 140 kg	1 200 kg

FEED UNIT OPTIONS

FEED MOTOR OPTIONS				
Fixed	250/315/400 cm ³	250/315/400 cm ³	400/500/500 cm ³	400/500/500 cm ³
Moving	400/500/630 cm ³	400/500/630 cm ³	630/780/800 cm ³	630/780/800 cm ³
Power output	15.8/19.7/24.9 kN	17.7/22.1/27.8 kN	23.7/30.2/30.2 kN	23.7/30.2/30.2 kN
Max. speed	4.5–6.0 m/s	4.5–6.0 m/s	4.5–6.0 m/s	4.5–6.0 m/s

FEED ROLLERS, FIXED	
	Steel spike, steel rib or V-profile steel

FEED ROLLERS, MOVING	
	Mense rubber steel, Moipu rubber steel, steel spike, V-profile steel, multi-tree handling

EUCALYPTUS EQUIPMENT				
	Yes	Yes	Yes	Yes

The manufacturer reserves the right to make changes. All product names featured in this brochure are registered trademarks of John Deere Forestry Oy.

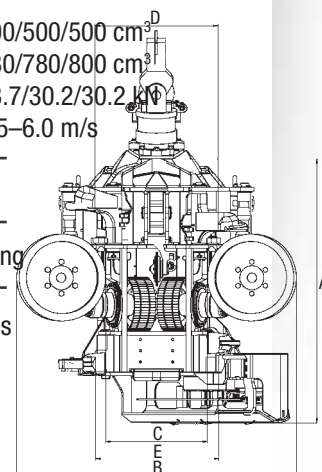

Technical Data

2 Rollers

FELLING/CUTTING	H742	H752	H270	H290
Saw motor	19 cm ³	19 cm ³	19 cm ³	19 cm ³
Length of saw bar	590 mm	750 mm	825 mm	900 mm
Cutting diameter	470 mm	570 mm	650 mm	750 mm
Chain type	0.404"	0.404"	0.404"	0.404"
Chain speed	40 m/s	40 m/s	40 m/s	40 m/s
Oil tank capacity	4 l	4 l	5 l	5 l
Saw options				
SuperCut	Yes	Yes	Yes	Yes
FlashCut	No	Yes	Yes	Yes

DELIMBING				
Delimiting knives				
Frame, upper knives	1 fixed	1 fixed	1 spring actuated	1 fixed
Above the feed rollers	2 moving	2 moving	2 moving	2 moving
Beneath the feed rollers	1 moving	2 moving	2 moving	2 moving
Frame, lower knives	1 fixed	1 fixed	1 fixed	1 fixed

MEASURING				
Length	Spike roller with hydraulic weighting			
Diameter	From front delimiting knives	From rear delimiting knives	From rear delimiting knives	From rear delimiting knives

ACCESSORIES				
Colour marking				
2 colours, saw bar	Yes	Yes	Yes	Yes
3 colours, saw bar	Yes	Yes	No	No
Stump treatment	Via the saw bar	Via the saw bar	Via the saw bar and a nozzle	Via the saw bar and a nozzle
Other accessories	For more information on the accessories, please contact our resellers.			

MEASUREMENTS* [mm]				
A Length of the delimiting unit	1 320	1 500	1 585	1 970
B Width with rollers open	1 270	1 410	1 660	1 900
C Opening, feed rollers	440	500	1 660	760
D Opening, upper delimiting knives	465	490	740	800
E Opening, lower delimiting knives	540	570	670	870

WEIGHT without rotator, from	H742	H752	H270	H290
	700 kg	930 kg	1 310 kg	1 850 kg

FEED UNIT OPTIONS

FEED MOTOR OPTIONS				
Moving	332/398 cm ³	514/560/625 cm ³	780/857/934 cm ³	1 259/944 or 1 404/1 050 cm ³
Power output	17.7/21.3 kN	25.1/27.3/30.5 kN	28.3/31.1/33.9 kN	37.3/28.1 or 41.6/31.2 kN
Max. speed	4.5–6.0 m/s	4.5–6.0 m/s	4.5–6.0 m/s	4.5–6.0 m/s

FEED ROLLERS, MOVING	Mense rubber steel, Moipu rubber steel, steel spike, Tierco rubber roller			
----------------------	---	--	--	--

EUCALYPTUS EQUIPMENT	H742	H752	H270	H290
	No	No	Yes (H270E)	No

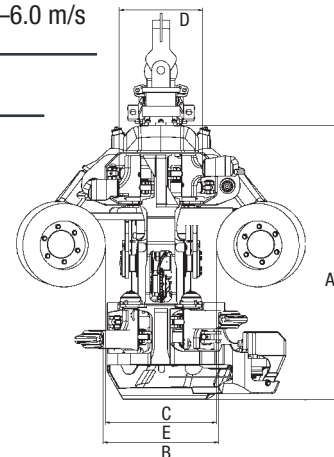

* Please note: the measurements are guidelines only and may vary depending on the production tolerances.

John Deere spearheads the global forest machine market. We offer the best options for a variety of conditions found in both cut-to-length and full-tree harvesting anywhere in the world. Our extensive sales and maintenance network is at your service near you.



JOHN DEERE

Nothing Runs Like A Deere

John Deere Forestry Ltd.
Carlisle Airport Industrial Estate
Carlisle, Cumbria CA6 4NW
United Kingdom
Tel. +44 (0) 870 224 3745
Fax. +44 (0) 870 224 3746
www.johndeere.co.uk

John Deere Forestry Ltd.
Ballyknocken
Glenealy
Co. Wicklow, Ireland.
Tel. (0) 404 44969
Fax. (0) 404 44972
www.johndeere.co.uk