

CAN

ereihani@yahoo.com

s_khosro2003@yahoo.com

1M Bit/s

CAN

CSMA

) 1M Bit/s

CAN.

(

¹ Controller Area Network

:
CAN

ABS

Robert Bosch

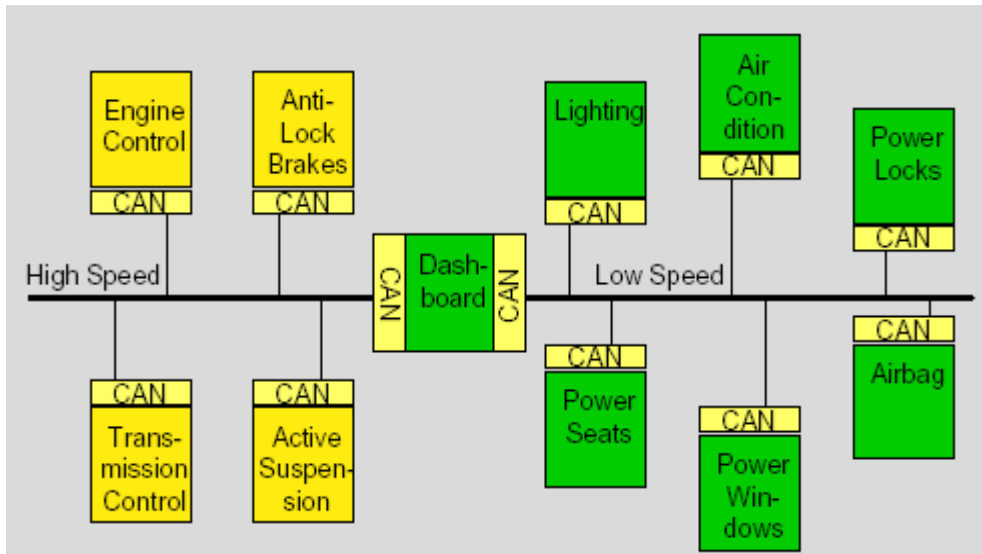

:CAN

CSMA

CSMA/CD (Carrier Sense Multiple Access)

CAN

()

Collision Detection CD

CAN

A,B,C

B

A,C

C

B

A

A

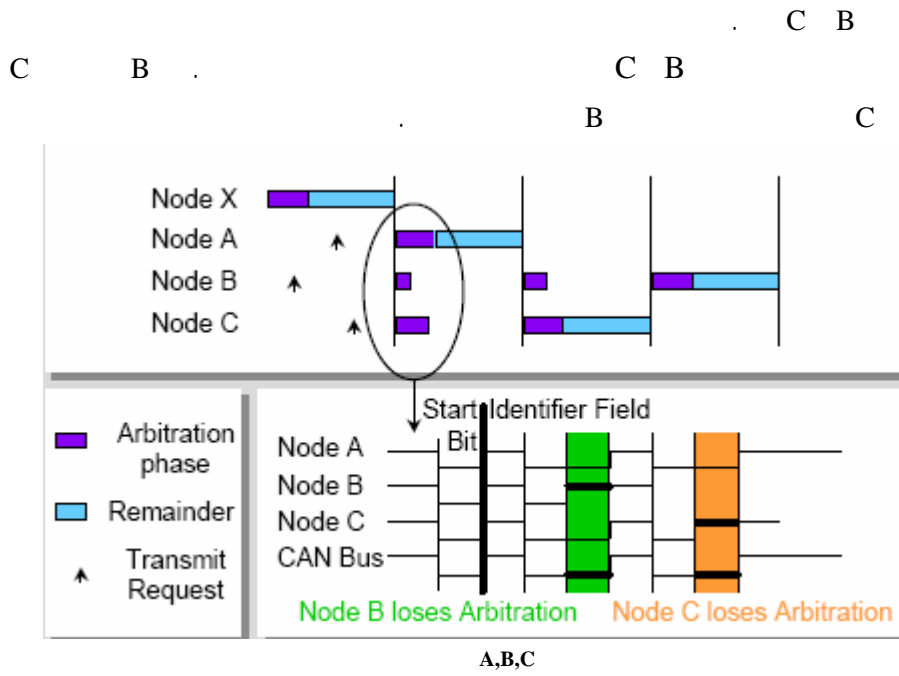

CAN

CAN

CAN

CAN

CAN

()

CRC

CAN

CAN

CAN
(RTR)

:CAN

RTR () CAN
 IDE ()
 CRC ()
 ACK
 "Intermission"

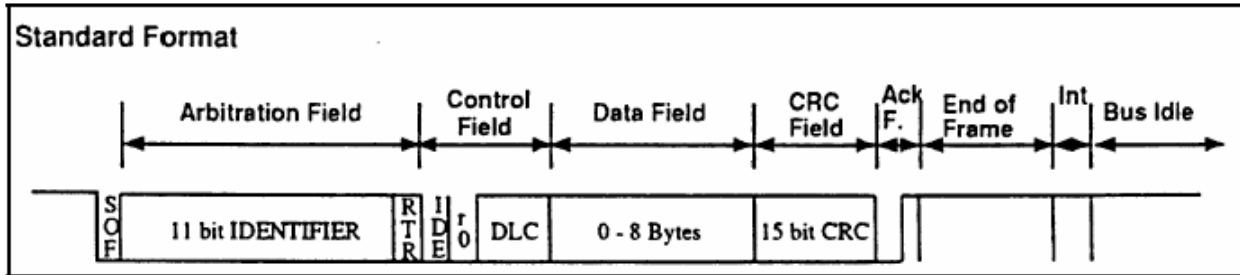

CAN

:CAN

Extended CAN IDE

Base

:(Cyclic Redundancy Check) CRC

CRC Check

CRC

:Frame Check

Format Error

CAN

CAN

NRZ(Non Return to Zero)

(IVN)

CAN

CAN

CAN

CAN.

CAN

CAN

CAN

CSMA/CD.

CAN

CAN

[1]: www.can-cia.org

[2]: www.kvase.com

[3]: www.microchip.com

[4]: www.intel.com

[5]: www.dgtech.com